

FINISHING: AS CAST / SANDBLASTED  
 BREAK ALL SHARP CORNERS / DEBURRS

ITEM	QTY	MATERIAL/TREATMENT	WEIGHT
1		ALUMINIUM COULÉ AVEC TRAITEMENT THERMIQUE	

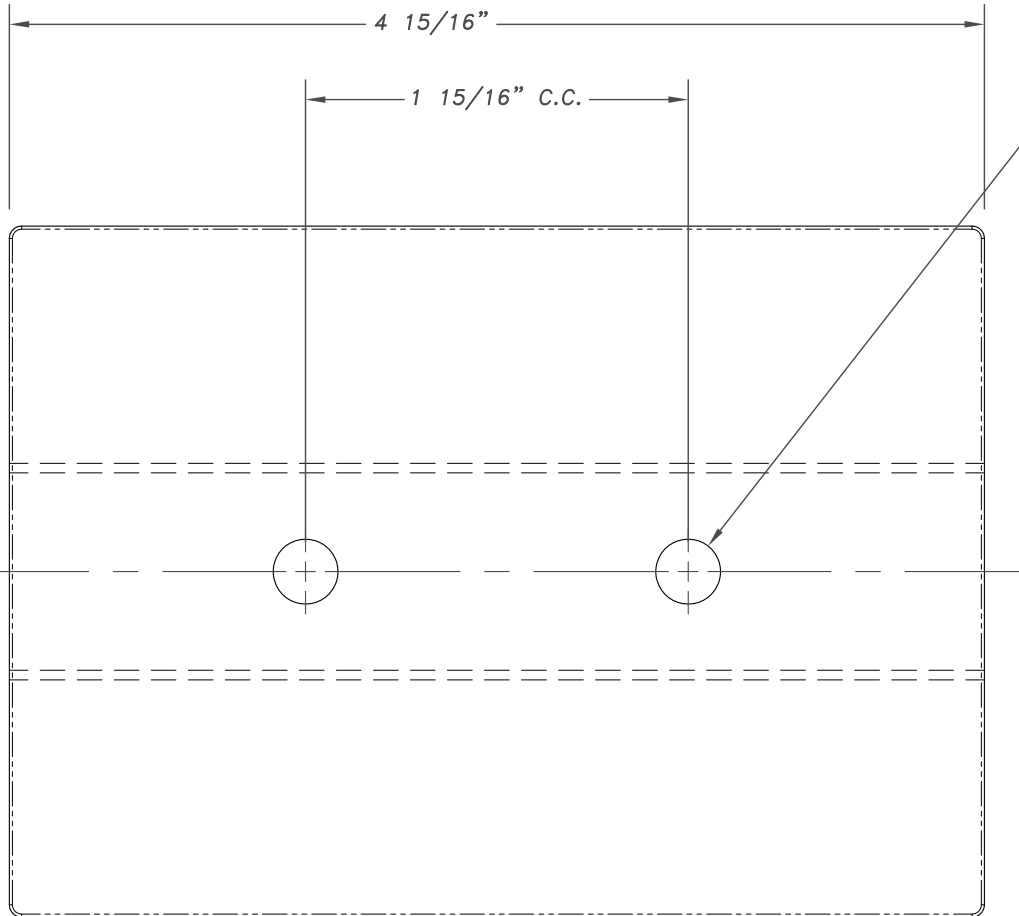

DRILL  $\varnothing 21/64$ " THRU ALL  
 TYP. 2PL.

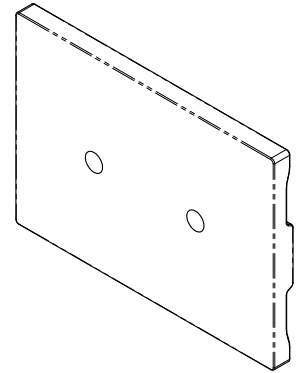
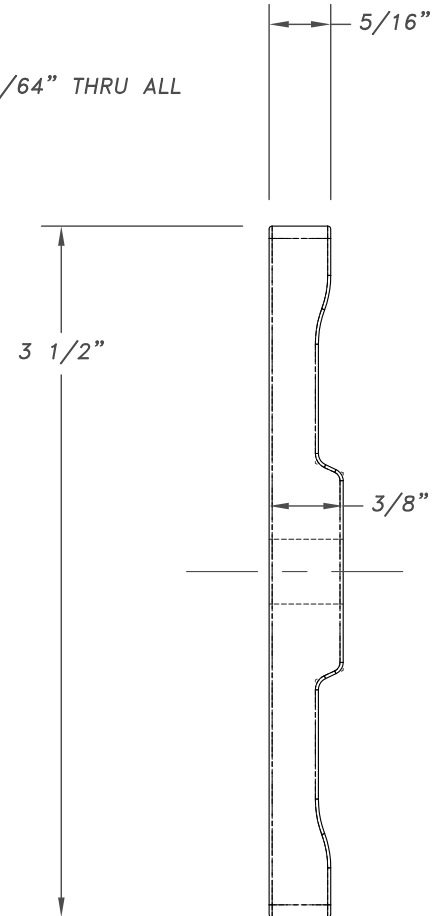

**NOTICES**

**NOTES & GENERAL TOLERANCES**

CAST DIMENSIONS (SAND):  
 FROM 0" TO 2":  $\pm 1/32$ "  
 FROM 2" TO 4":  $\pm 3/64$ "  
 FROM 4" & MORE:  $\pm 1\%$

MACHINED DIMENSIONS:  
 FRACTIONS:  $\pm 1/64$ "  
 .X:  $\pm .010$ "  
 .XX:  $\pm .007$ "  
 .XXX:  $\pm .003$ "  
 ANGLES:  $\pm .5^\circ$   
 THESE TOLERANCES ARE NOT CUMULATIVE

(IF NOT INDICATED)

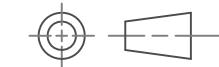

NORTH AMERICAN VIEW

IMPERIAL  
 MEASUREMENT

SCALE:

1:1

DATE:

DRAWN BY:

VERIFIED BY:

APPROVED BY:



900, boul. de la Commune  
 Trois-Rivières QC G9A 2W6  
 TEL.: 819 378-2765  
 FAX: 819 378-1883  
 SANS FRAIS: 1 800 567-8551  
 E-MAIL: info@spectralite

3781, rue La Fayette Ouest  
 Boisbriand QC J7H 1N5  
 FAX: 450 419-0008  
 SANS FRAIS: 1 800 567-8551  
 E-MAIL: info@spectralite

CUSTOMER:

PROJECT: JUNCTION PLATE (MET 16)  
 FABRICATION DRAWING

REVISION :

REVISION-00

DRAWING NO.:

0679PMET16-01

A